

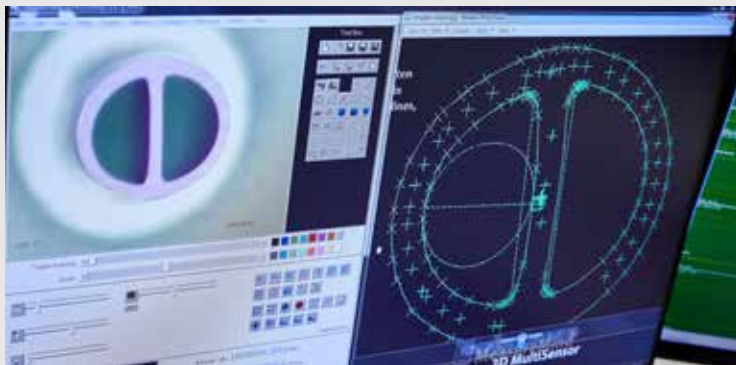

BIOMERICS™
— ADVANCED EXTRUSION —



PROVIDING HIGH-END EXTRUSION DESIGN, DEVELOPMENT & MANUFACTURING SOLUTIONS FOR THE MEDICAL DEVICE MARKET



Biomerics Advanced Extrusion produces thermoplastic extrusions that meet the most precise specifications for demanding clinical applications within the cardiovascular, structural heart, cardiac rhythm management, electrophysiology, neurovascular, vascular access, and pain management markets.

Through close collaboration with our customers, we can manufacture complex multi-lumen extrusions, co-extrusions, and bump or taper tubing configurations, and a variety of other options, all of which are used in a wide range of advanced medical procedures.

Our team of Engineers, are leaders in the extrusion field and bring over 60 years of combined experience to Biomerics. We are constantly working to find new ways to implement new knowledge, trends, and technologies into all of our catheter extrusion design, development, and manufacturing processes.

It is our goal to utilize the best materials, employ the brightest minds and ensure the projects entrusted with us, offer our customers leading edge technology and design skills that will create success for you, your products and market of choice.



Single Lumen Tubing

The most common of all extrusions, a single lumen tube consists of a single channel that can vary in size, shape, material, and dimension. Biomerics offers a full range of ID/OD configurations ranging from 0.001 up to diameters as large as 1.00"



Multi-Lumen Tubing

We supply a wide range of dual and triple lumen extrusions in straight and bump configurations. This includes standard profiles such as double D, Y, double bore, bi-lumen, circle in a circle, and tri-lumen. Common applications include dialysis catheters, PICCs, CVC, ports, fluid management, air lines, drug delivery, cooling lines, and protectors.

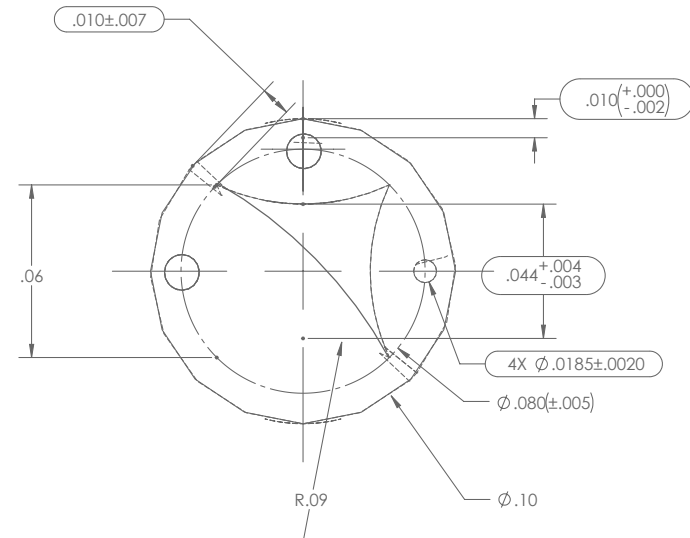

Quality Commitment:

Biomerics Advanced Extrusion strives to provide superior service while manufacturing products that meet or exceed our customer's expectations. We manufacture products in ISO 13485 and FDA compliant facilities under a robust quality management system.

MANUFACTURING



Our cleanrooms are ISO Class 8 (100,000) certified

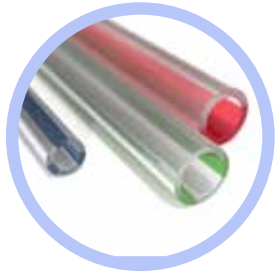

Co-Extrusion

Co-extrusion, or multi-layer extrusion, involves the process of layering or embedding multiple materials into a single extrusion. These complex tube constructions allow engineers to obtain the combined properties of multiple materials within a single tube. We have the ability to utilize up to four materials at the same time in any given extrusion. At Biomerics, we specialize in a variety of co-extrusions, including:

- Striping
- Tie-Layering
- Transition Extrusion
- Multi-Durometer
- Over Extrusion/Jacketing

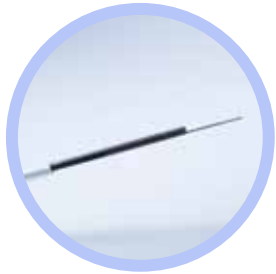

Jacketing

Jacketing is used to add a range of properties to an extrusion. These properties include: Insulation, Impact Resistance, Elongation, Lubricity, Kink Resistance, Tensile Strength. We can jacket fiber optics, polymer extrusions, and wire in both reel-to-reel and manual mandrel processes. These extrusions can also include lumens and co-extruded materials.



Bump (Tapered) Extrusion

Bump, taper, and draw down tubes vary in diameter over the length of the extrusion. These extrusions are commonly used when different functionality is required at the proximal and distal end of a catheter or device. Biomerics has the capability to vary the number and size of bumps along the length of the extrusion, as well as the wall thickness between the inside and outside diameters. Combined with our multilayer and multi-lumen technologies, the potential number of configurations is endless.

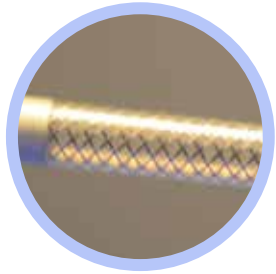

Braided, Coil Tubing & Shafts

We provide industry leading medical device companies with braided and coiled catheter and delivery device shaft solutions. Our braiding capabilities range from .75 French (Fr) Outside Diameter (OD) to 32Fr, with wall thickness as low as 0.005". Our braiding processes include vertical reel-to-reel continuous braiding and precision horizontal mandrel braiding. We can braid a wide range of material reinforcements including:

- Stainless Steel
- Nitinol
- Monofilament Nylon
- Kevlar and other specialty polymers.

For more information about our extrusion capabilities, engineering, quality, or regulatory solutions visit <http://biomerics.com/manufacturing/extrusion/> or give us a call at 763.428.0010

PRODUCTS

Secondary Assembly



Used to print, mark, and brand uniquely shaped medical devices and components.

Pad Printing or Laser Marking

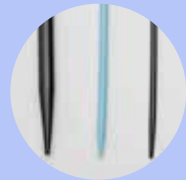

Aid in the insertion and guidance of devices such as catheters and introducers.

Tipping



Hole punching, skiving, laser cutting, and drilling processes are used to create access points within an extruded tube.

Punching, Skiving & Drilling



Medical balloons are found across a wide range of medical devices, and used across many medical applications.

Balloons

Materials

Biomerics Advanced Extrusion offers a range of medical grade quality thermoplastic polymers, which enables us to be a preferred extrusion provider for the medical device industry. Below is a list of materials we commonly work with, including:

FEP - Fluorinated Ethylene Propylene

LDPE & HDPE - Low & High-Density Polyethylene

TPU - Thermoplastic Urethanes

Nylon 11 & 12, Pebax

ETFE - Ethylene Tetrafluoroethylene

FEP - Fluorinated Ethylene Propylene

PFA - Perfluoroalkoxy Alkene

PVDF (Kynar) - Polyvinylidene Fluoride

ETFE (Tefzel) - Ethylene Tetrafluoroethylene

PTFE - Polytetrafluoroethylene

PEEK - Polyether Ether Ketone

PA - Polyamide

PE - Polyethylene

PUR - Polyurethane

POM - Polyoxymethylene

PVC - Polyvinyl chloride

Quadra Family

Quadrasil - ARS, Elast-Eon, ECSiL

Quadraflex - ALE, ARE

Quadrathane - ALC, ARC

Quadraplast - Rigid AR

Prolix™



Our Prolix™ line of medical fluid management tubing is designed for a wide range of procedural applications. Our high pressure, low pressure, and pressure monitoring tubing is available in various sizes, materials, and reinforcements.

Our standard Prolix™ line includes:

- Prolix™ HPBT 1,200 psi. Quadraflex™ High Pressure Braided Tubing
- Prolix™ HPCE 1,200 psi. High Pressure Co-Extruded Tubing
- Prolix™ HPC 1,000 psi. High Pressure non-DEPH PVC Tubing
- Prolix™ LPC 500 psi. Low Pressure non-DEPH PVC Tubing

We have the capacity and capability to customize your tubing and assembly. If our variety of standard sizes doesn't meet your needs, we are happy to tailor an extrusion to your specifications.

“ We are constantly working to find new ways to implement new knowledge, trends, and technologies into all of our catheter extrusion designs. ”

OUR MARKET FOCUS

INTERVENTIONAL CARDIOLOGY & RADIOLOGY

- Procedural Devices
- Fluid Management Systems
- Imaging & Diagnostic Catheters
- Drainage Catheters
- Thrombectomy Catheters
- Atherectomy Catheters
- Embolization Catheters
- Balloon Catheters
- Delivery Catheters

VASCULAR ACCESS

- Procedural Devices
- Peripheral Catheters
- Central Venous Catheters
- Ports
- Hemodialysis Catheters

PAIN MANAGEMENT

- Neuroablation Devices
- Neurostimulation Devices
- Access Catheters

NEUROVASCULAR

- Micro-Catheters
- Coil Delivery Systems
- Thrombectomy Catheters
- Embolization Catheters
- Access Catheters

STRUCTURAL HEART

- Heart Access Systems
- PFO Closure Delivery Systems
- Valve Delivery Systems
- Introducers
- Sheaths
- Balloon Catheters

CARDIAC RHYTHM MANAGEMENT & ELECTROPHYSIOLOGY

- Pacing Leads
- Mapping Catheters
- Ablation Catheters
- Cryotherapy Catheters
- Placement Devices

GASTROINTESTINAL

- Endoscopes (Rigid, Flexible)
- Stents
- Bariatric Surgery Devices
- Hemostasis
- Feeding Pumps
- Esophageal Devices
- Dilatation/Balloons
- Urology/Gynecology Devices
- Access Devices

Design & Engineering Solutions

Our engineering capabilities and experience allow us to support our customers' projects from concept through full scale production. The Biomerics Product Development Process™ and Biomerics Product Transfer Process™ both utilize a stagegate approach to ensure that all design, manufacturing, regulatory, and quality requirements for a medical device are planned for and met. We provide world-class engineering expertise, testing labs, and process development and validation services for leading medical device companies. Our design and engineering capabilities include:

- Design Development
- Product & Design Transfer
- Scientific Injection Molding
- Lab & Testing Services
- Animal Testing Support
- Full Project Management

Quality & Regulatory Services

Whether our customers are working with us to develop a new device or transfer an existing product line, we partner with them through every stage of the regulatory process. We have experience and expertise with FDA, CE Mark, and various other regulatory body submission requirements, and we are always ready to help bring life-saving devices to market as efficiently as possible. Our quality and regulatory services include:

- Testing & Validation
- DHF & DMR Documentation
- Process Development & Validation
- Packaging Design & Validation
- IQ, OQ & PQ Validation
- Patent Services
- Clinical Support

CONTACT US



**Biomerics Advanced Extrusion
Biomerics Advanced Laser
Biomerics Advanced Catheter**
10351 Xylon Ave. N., Suite 100
Brooklyn Park, MN 55445

Phone: 763.428.0010
Email: csr@biomerics.com
biomerics.com

Biomerics, LLC.
2700 S 900 W., Suite D.
Salt Lake City, UT 84119

Phone: 801.355.2705
Email: csr@biomerics.com
biomerics.com

Biosonix
3487 West 2100 South
Salt Lake City, UT 84119

Phone: 801.975.7484
Email: support@bio-sonix.com
bio-sonix.com

Biomerics Advanced Extrusion is a member of the Biomerics Family of Companies. The Biomerics Family of Companies offers the following solutions to the medical device and healthcare industries.



- Quadra™ Family of Polyurethanes
- Prolix™ Medical Fluid Management Tubing
- Polymerization & Compounding
- Device Dipping, Imbibing & Coating
- Medical Grade Extrusion
- Ultrasonic Devices & Components

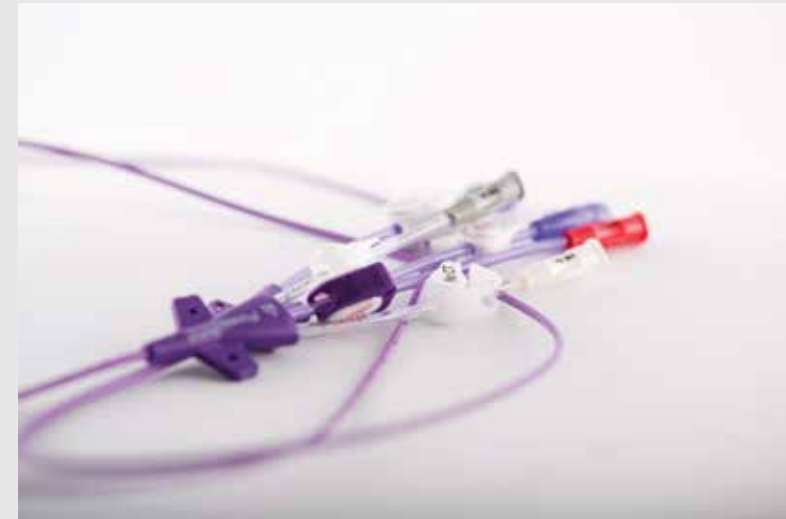

- Cleanroom & Non-Cleanroom Injection Molding
- Finished Device Assembly
- Packaging, Sterilization Management & Fulfillment
- Design & Development Engineering
- Product Transfer Engineering
- Quality & Regulatory Services

A MEMBER OF THE BIOMERICS FAMILY OF COMPANIES

